

Hypertherm[®]

***Centricut[®] plasma torches
and consumables for
Kaliburn[®]***

 ad technology



Product is available for the following major OEM brands

AMADA®

ESAB®

KALIBURN®

KJELLBERG®

KOIKE®

KOMATSU®

LINCOLN®

THERMAL

DYNAMICS®

WHITNEY®

WIEDEMANN®

OEM Kaliburn®

System ProLine 2150, 2200, 2260
FineLine150, 200, 260

Consumables

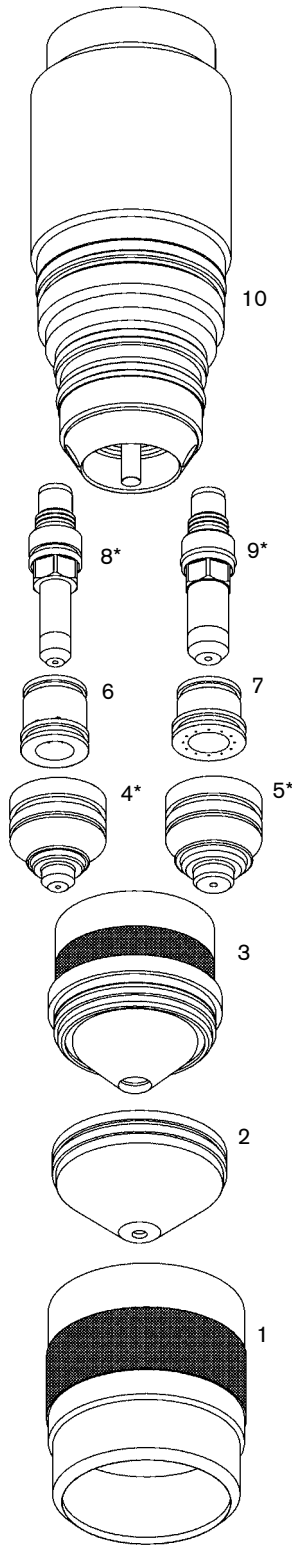

Centricut part number	Reference number	Description	Pkg qty
1 C107-154	277154	Outer cap	1
2 I107-145	277145	Shield cap, 30 amp, MS/AL	1
I107-144	277144	Shield cap, 30 amp, SS	1
C107-115	277115	Shield cap, 50 amp, MS	1
I107-149	277149	Shield cap, 50 amp, SS	1
C107-150	277150	Shield cap, 70 amp, MS/SS/AL	1
C107-147	277147	Shield cap, 100 amp	1
C107-117	277117	Shield cap, 150 amp, MS/SS/AL	1
C107-274	277274	Shield cap, 200 amp, MS/SS/AL	1
C107-148	277148	Shield cap, 200 amp, SS	1
C107-263	277263	Shield cap, 275 amp, MS/SS/AL	1
3 I107-110	277110	Retaining cap, 30/150 amp, SS	1
C107-153	277153	Retaining cap, 30/50/70 amp, MS/SS/AL	1
C107-151	277151	Retaining cap, 100/150 amp, MS/SS/AL	1
C107-152	277152	Retaining cap, 150 amp, MS/SS/AL	1
I107-113	277113	Retaining cap, 200 amp, SS	1
C107-266	277266	Retaining cap, 200/275 amp, MS/SS/AL	1
4 C107-122*	277122	CoolFlow™ nozzle, 50 amp, MS/AL	1
C107-125*	277125	CoolFlow nozzle, 70 amp, MS/SS/AL	1
C107-127*	277127	CoolFlow nozzle, 100 amp, MS	1
C107-119*	277119	CoolFlow nozzle 150 amp, MS	1
5 C107-268*	277268	CoolFlow nozzle, 200 amp, MS	1
C107-269*	277269	CoolFlow nozzle 275 amp, MS	1
I107-120	277120	Nozzle, 30 amp, MS/AL	1
I107-121	277121	Nozzle, 30 amp, SS	1
I107-123	277123	Nozzle, 50 amp, SS	1
I107-114	277114	Nozzle, 200 amp, SS/AL	1
I107-276	277276	Nozzle, 275 amp, SS/AL	1
6 I107-138	277138	Swirl ring, 30 amp, SS	1
I107-140	277140	Swirl ring, 30/70 amp, MS/SS/AL	1
C107-142	277142	Swirl ring, 50/70/100 amp, MS/SS/AL	1
C107-139	277139	Swirl ring, 150 amp, MS/SS/AL	1
7 C107-259	277259	Swirl ring, 200 amp, SS	1
C107-143	277143	Swirl ring, 200 amp, MS/SS/AL	1
C107-258	277258	Swirl ring, 275 amp, MS/SS/AL	1
I107-130	277130	Electrode, 30 amp, MS/AL	1
I107-137	277137	Electrode, 30/50 amp, SS	1
C107-131	277131	Electrode, 50/70 amp, MS/SS/AL	1
8 C107-1034*	277134	SilverLine® electrode, 100 amp, MS	1
9 C107-1036*	277136	SilverLine electrode, 150/200 amp, MS	1
C107-1070*	277270	SilverLine electrode, 275 amp, MS/SS/AL	1
I107-190	277190	Electrode, marking	1

Maintenance items

Centricut part number	Reference number	Description	Pkg qty
10 I107-7000	277000	Torch body	1
I104-024	500024	O-ring, blue	1
I104-018	500018	O-ring, orange	1
I104-209	820209	O-ring, orange	1
I107-007	277007	Cooling tube	1
I107-105	260105	Swirl ring removal tool	1
I107-056	277056	Nozzle removal tool	1
027055	N/A	Lubricant .25 oz. (7 ml) tube	1

* Centricut part features a unique Hypertherm design that differs from the OEM design.

Many of these parts can be used with the Kaliburn Spirit systems. Contact Hypertherm for details and assistance with part selection.

Centricut and SilverLine are registered trademarks of Hypertherm, Inc. and may be registered in the United States and/or other countries. All other trademarks are the properties of their respective owners. Centricut is in no way affiliated with Kaliburn.

OEM Kaliburn[®] System SR-45i[®]

Consumables

Centricut part number	Reference number	Description	Pkg qty
1 I36-098	770098	Retaining cap	1
2 C36-030	770030	Nozzle, insulation	5
3 C36-104	770104	Nozzle, tapered	5
4 C36-000	770000	Nozzle, Air	5
5 C36-012	770012	Swirl ring	1
6 C36-715*	770015/ 770017	Electrode, Air	5

Maintenance items

Centricut part number	Reference number	Description	Pkg qty
I36-073	770073	Torch body	1
136-072	770072	O-ring	5
027055	N/A	Lubricant .25 oz. (7 ml) tube	1

* Centricut part features a unique Hypertherm design that differs from the OEM design.

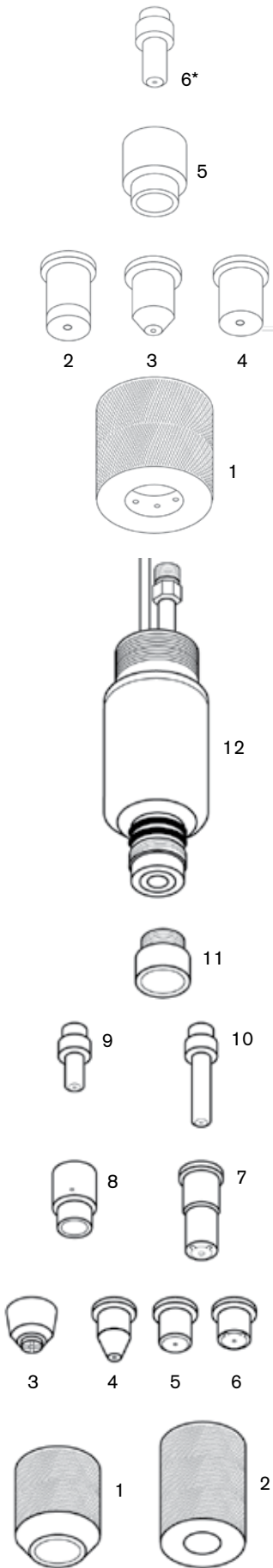

SR-45i[®] Retrofit

OEM Kaliburn[®] System SR-45i[®] Retrofit

Consumables

Centricut part number	Reference number	Description	Pkg qty
1 020200	020200	Retaining cap, high visibility	1
2 C02-104	020104	Retaining cap	1
3 020197	020197	Nozzle, high visibility	5
4 C02-131	020131	Nozzle, pipe	10
5 C02-102	020102	Nozzle	10
6 C02-115	020115	Nozzle	10
7 020466	020466	Nozzle, extended	5
8 020340	020340	Nozzle, gouging	5
9 C02-101	020101	Swirl ring	2
10 020167	020167	Electrode, N ₂	5
10 020467	020467	Electrode, Air, extended	5

Maintenance items

Centricut part number	Reference number	Description	Pkg qty
C02-016	044016	O-ring	5
11 C02-043	N/A	Insulator, replaceable	1
12 C36-973	N/A	Retrofit modular torch body	1
027055	N/A	Lubricant .25 oz. (7 ml) tube	1



**Technology products for ESAB[®],
Kjellberg[®] and Kaliburn[®]**

Hypertherm[®]

Cut with confidence™

Hypertherm, Inc.
Hanover, NH 03755 USA
603-643-3441 Tel

Hypertherm (S) Pte Ltd.
Singapore 349567
65 6841 2489 Tel

**Hypertherm (Shanghai)
Trading Co., Ltd.**
PR China 200052
86-21 5258 3330 /1 Tel

Hypertherm Europe B.V.
4704 SE Roosendaal, Nederland
31 165 596907 Tel

HYPERTHERM BRASIL LTDA.
Guarulhos, SP - Brasil
55 11 2409 2636 Tel

www.hypertherm.com



Hypertherm and Centricut are registered trademarks of Hypertherm, Inc. and may be registered in the United States and/or other countries. All other trademarks are the properties of their respective owners.