

Hypertherm®

powermax1250® G3 SERIES™

Machine torch parts

T80 consumables



Powermax1250



T80M torch

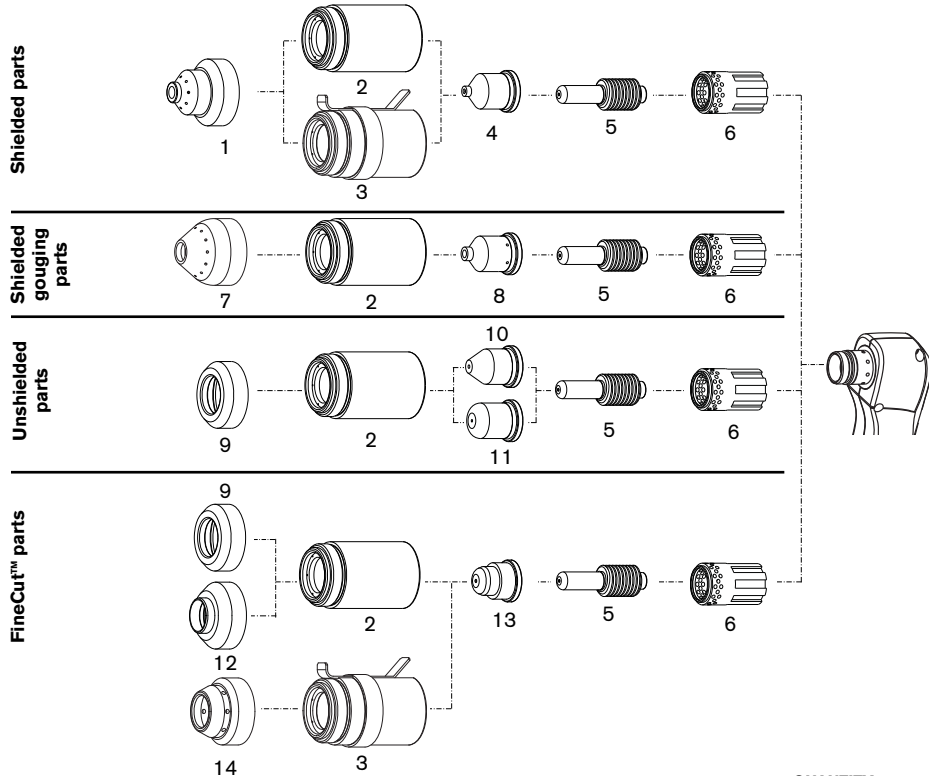

	ITEM NUMBER	PART NUMBER	DESCRIPTION	QUANTITY PER PACKAGE
Shielded parts	1	120930	Shield	1
	2	120928	Retaining cap	1
	3	220061	Retaining cap, ohmic	1
	4	120927	Nozzle, 80 amp	5
	4	120931	Nozzle, 60 amp	5
	4	120932	Nozzle, 40 amp	5
Shielded gouging parts	5	120926	Electrode	5
	6	120925	Swirl ring	1
	7	120977	Shield, gouging	1
	2	120928	Retaining cap	1
Unshielded parts	8	220059	Nozzle, gouging	5
	5	120926	Electrode	5
	6	120925	Swirl ring	1
	9	120979	Deflector	1
	2	120928	Retaining cap	1
	10	120980	Nozzle, extended, 80 amp	5
FineCut™ parts	10	220007	Nozzle, extended, 60 amp	5
	11	220006	Nozzle, extended, 40 amp	5
	5	120926	Electrode	5
	6	120925	Swirl ring	1
	9	120979	Deflector	1
	12	220325	Deflector, CE	1
Shielded parts	14	220404	Shield, ohmic	1
	2	120928	Retaining cap	1
	3	220061	Retaining ring, ohmic	1
	13	220329	Nozzle	5
	5	120926	Electrode	5
	6	120925	Swirl ring	1

Genuine Hypertherm Consumables

The only way to ensure maximum performance

WARNING

In countries following CE standards, shielded consumables must be used for hand cutting applications.

Unshielded consumables: maintain torch-to-work distance of approximately 3/16" (4.8 mm).

Powermax1250 T80M torch assembly

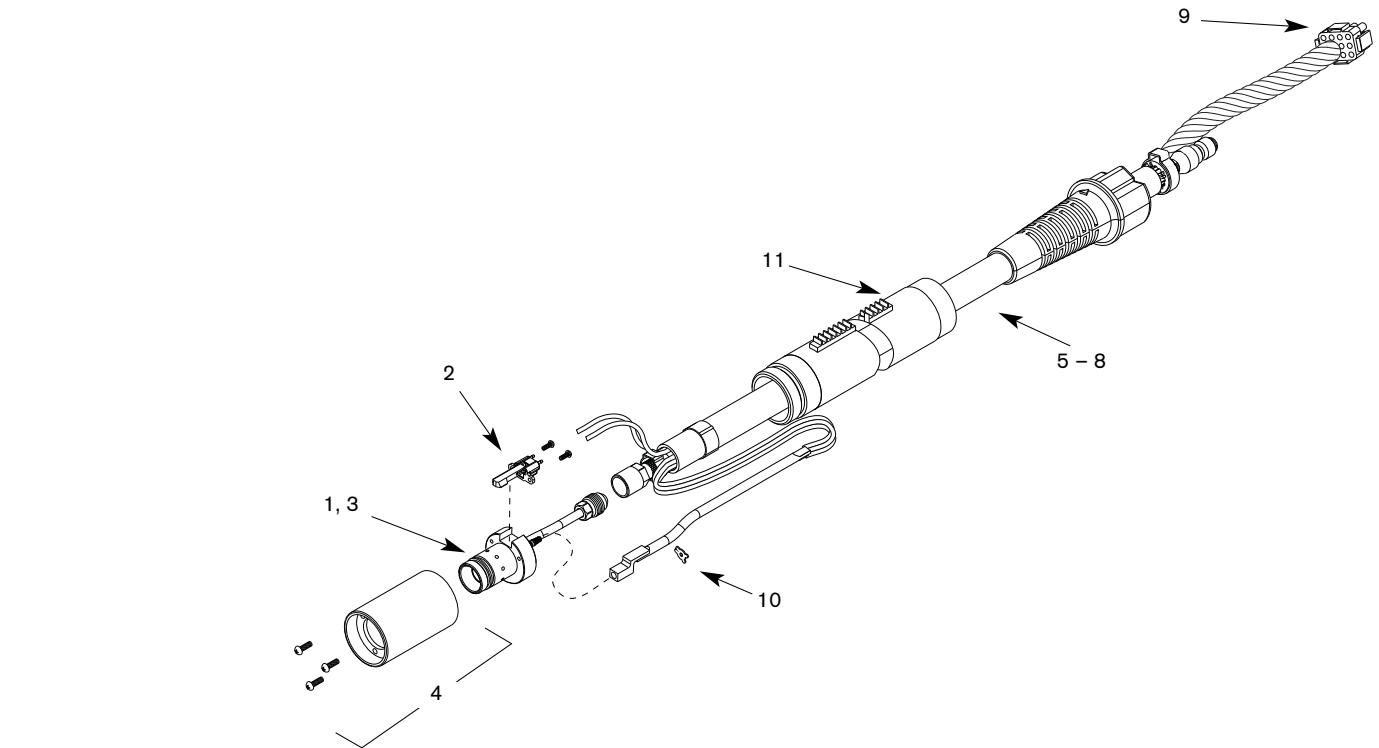

T80M torch

ITEM NUMBER	PART NUMBER	DESCRIPTION
	087003^	T80M machine torch assembly with 15' / 4.6 m lead
	087004^	T80M machine torch assembly with 25' / 7.6 m lead
	087005^	T80M machine torch assembly with 35' / 10.7 m lead
	087006^	T80M machine torch assembly with 50' / 15.2 m lead
	128645	Kit: Torch mounting
1	128640	Kit: T80M torch main body replacement
2	128639	Kit: Cap sensor switch replacement
3	128521	Kit: T60/T80/T60M/T80M torch head repair
4	128643	Kit: T60M/T80M mounting sleeve replacement
5	128634	Kit: T80M lead replacement, 15' / 4.6 m
6	128633	Kit: T80M lead replacement, 25' / 7.6 m
7	128635	Kit: T80M lead replacement, 35' / 10.7 m
8	128641	Kit: T80M lead replacement, 50' / 15.2 m
9	128638	Kit: ETR connector repair (Regional Repair Centers only)
10	027889	Retaining clip
11	128710	T60M/T80M positioning sleeve replacement

^ Assembly includes consumables

Hypertherm, Powermax, G3 Series, FineCut and PAC are trademarks of Hypertherm, Inc. and may be registered in the United States and/or other countries.

Hypertherm®

www.hypertherm.com

Hypertherm, Inc. USA 603-643-3441 Tel 603-643-5352 Fax manual.info@hypertherm.com

Hypertherm Automation USA 603-298-7970 Tel 603-298-7977 Fax info@hyperthermautomation.com

Hypertherm Plasmatechnik GmbH Deutschland 49 6181 58 2100 Tel 49 6181 58 2134 Fax HTDeutschland.info@hypertherm.com

Hypertherm (S) Pte Ltd. Singapore 65 6841 2489 Tel 65 6841 2490 Fax HTSingapore.info@hypertherm.com

Hypertherm (Shanghai) Trading Co., Ltd. PR China 86-21 5258 3330 /1 Tel 86-21 5258 3332 Fax HTChina.info@hypertherm.com

Hypertherm Branch of Hypertherm UK, LLC England 00 800 3324 9737 Tel 00 800 4973 7329 Fax HTUK.info@hypertherm.com

France (Representative office) 00 800 3324 9737 Tél 00 800 4973 7329 Fax HTFrance.info@hypertherm.com

Hypertherm Europe B.V. Nederland 31 165 596907 Tel 31 165 596901 Fax HTEurope.info@hypertherm.com

Hypertherm Japan Ltd. 81 6 6170 2020 Tel 81 6 6170 2015 Fax HTJapan.info@hypertherm.com

Hypertherm Brasil Ltda. 55 11 2409 2636 Tel 55 11 2408 0462 Fax HTBrasil.info@hypertherm.com

Hypertherm México, S.A. de C.V. 52 55 5681 8109 Tel 52 55 5683 2127 Fax ventas@hypertherm.com.mx

Australia/New Zealand (Representative office) 61 (0) 7 3219 9010 Tel 61 (0) 7 3219 9012 Fax sales.au@hypertherm.com